

KNOB-LB-250-1

MATERIAL. --
 FINISH. --
 COLOR.

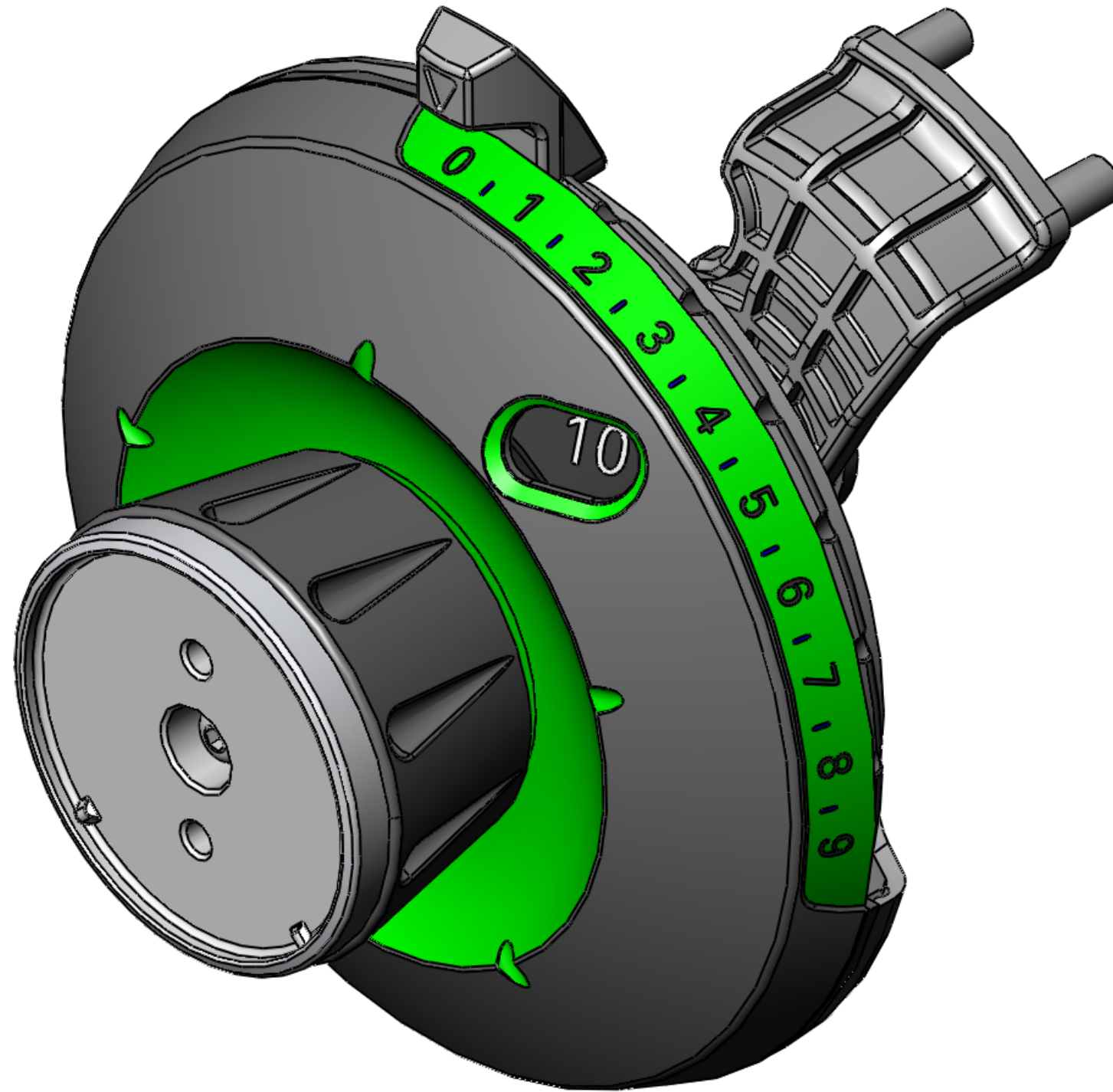

REVISIONS				
ECO	REVISION	REV DESCRIPTION	APPROVED	DATE
062607-A	A	INITIAL RELEASE	--	6/26/2007
062607-A	B	INITIAL RELEASE	--	10/1/2007

ITEM NO.	PART NUMBER	QTY.	DESCRIPTION
1	09-1217	1	Handle Adjustment Knob Mount "ONE"
2	04-2081	1	Washer Steel 1.0ID x 1.5OD x 0.125L
3	09-1223	1	Handle Adjustment Knob Weight "ONE"
4	08-5084	1	Washer PL 1.0ID x 1.5OD x 0.0625L
5	09-1221	1	Hub Weight Number "ONE"
6	09-1218	1	Handle Adjustment Add-on "ONE"
7	09-1238	1	Plate Indicator Numbers 250 "ONE"
8	09-1233	1	Shield Bezel 1lb increments "ONE"
9	05-5113	2	IGUS FLANGE 1 ID x 1.125 OD x .5L
10	02-9047	2	6 -32 UNC THREAD x 1/2" LENGTH PAN HEAD PHILLIPS SCREW
11	01-4061	1	BUTTON HEAD SOCKET CAP SCREW 1/4 -20 x 1" BRIGHT ZINC
12	04-1008	2	WASHER, FLAT, #6 SAE

NAUTILUS
 NAUTILUS, INC.
 16400 SE NAUTILUS DRIVE, VANCOUVER, WA 98683

UNLESS OTHERWISE SPECIFIED:
 1. ALL DIMENSIONS APPLY BEFORE PLATING OR COATING.
 2. REMOVE ALL BURRS, BREAK SHARP EDGES .020 IN MAX.
 3. ALL MACHINED SURFACES Ra 125 uIN.
 3. ALL APPLICABLE NAUTILUS STANDARDS AND SPECIFICATIONS APPLY.

INCH
 THIRD ANGLE PROJECTION

TOLERANCES.
 X. ± .125
 X.X ± .020
 X.XX ± .010
 X.XXX ± .005
 XX ± 1/64
 ANGULAR ± 1°
(INTERPRET DIMENSIONS AND TOLERANCES PER ASME Y14.5M - 1994)

DESIGNED G.WEBB
 DRAWN G.Webb
 DATE 04/19/2007
 DO NOT SCALE DRAWING

TITLE: **Weight Select Knob Assy**
 SIZE PART NO. **B KNOB-LB-250-1** REV. **B**

KNOB-LB-250-1

MATERIAL. --
 FINISH. --
 COLOR.

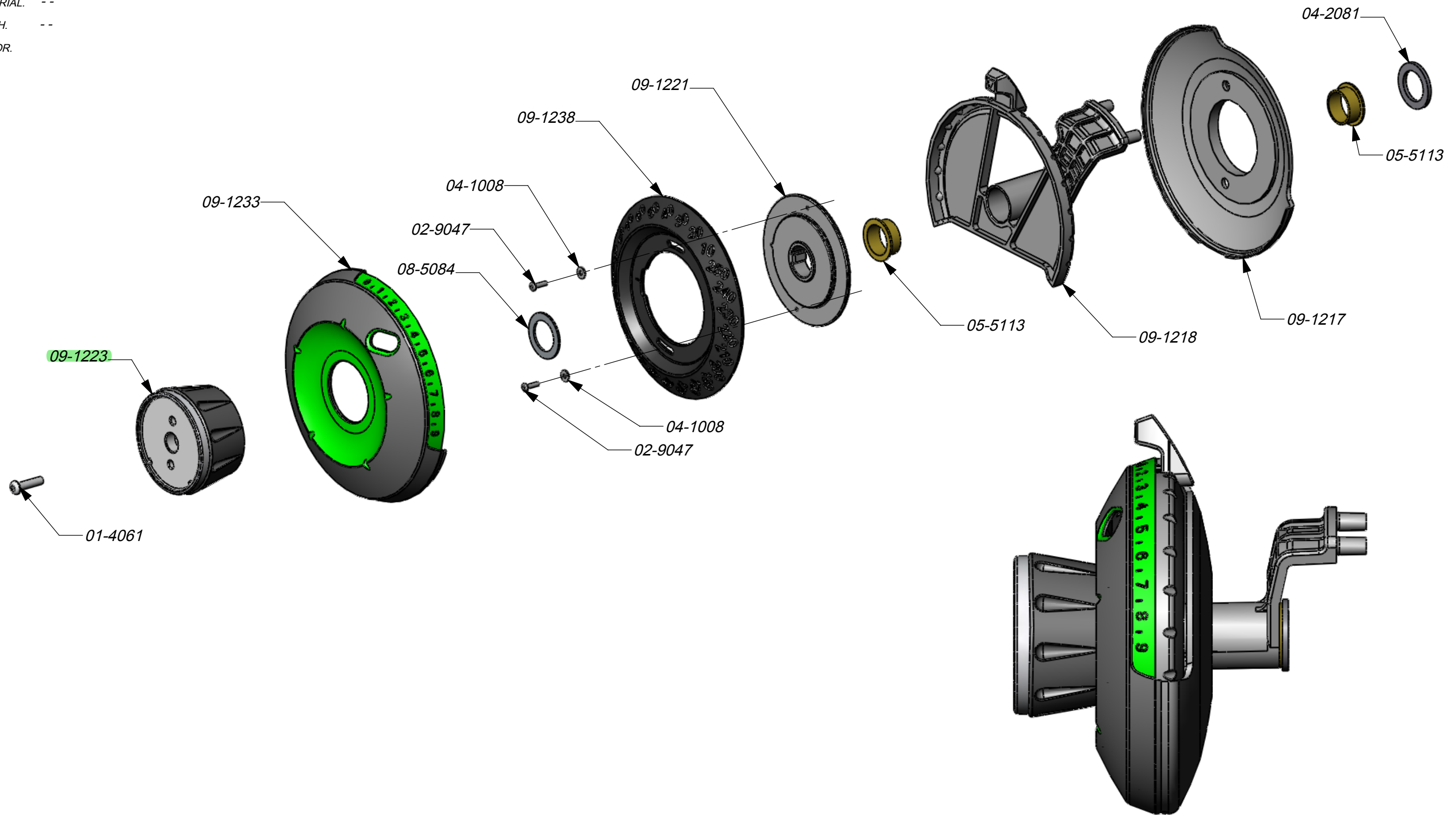

NAUTILUS
 NAUTILUS, INC.
 16400 SE NAUTILUS DRIVE, VANCOUVER, WA 98683

UNLESS OTHERWISE SPECIFIED:
 1. ALL DIMENSIONS APPLY BEFORE PLATING OR COATING.
 2. REMOVE ALL BURRS, BREAK SHARP EDGES .020 IN MAX.
 3. ALL MACHINED SURFACES Ra 125 uIN.
 3. ALL APPLICABLE NAUTILUS STANDARDS AND SPECIFICATIONS APPLY.

INCH
 THIRD ANGLE PROJECTION

TOLERANCES.
 X. ± .125
 X.X ± .020
 X.XX ± .010
 X.XXX ± .005
 X/X ± 1/64
 ANGULAR ± 1°
(INTERPRET DIMENSIONS AND TOLERANCES PER ASME Y14.5M - 1994)

DESIGNED	G.WEBB
DRAWN	G.Webb
DATE	04/19/2007

DO NOT SCALE DRAWING

TITLE	Weight Select Knob Assy	
SIZE	PART NO.	REV.
B	KNOB-LB-250-1	B