

002-2438

- SERVICE PART ITEM: PKG. (1) ASSY / POLY-BAG

		REVISIONS		
ECO NUMBER	REVISION	REV DESCRIPTION	APPROVED	DATE
12489	A	DRAWING RELEASE	CRW	6/26/2009

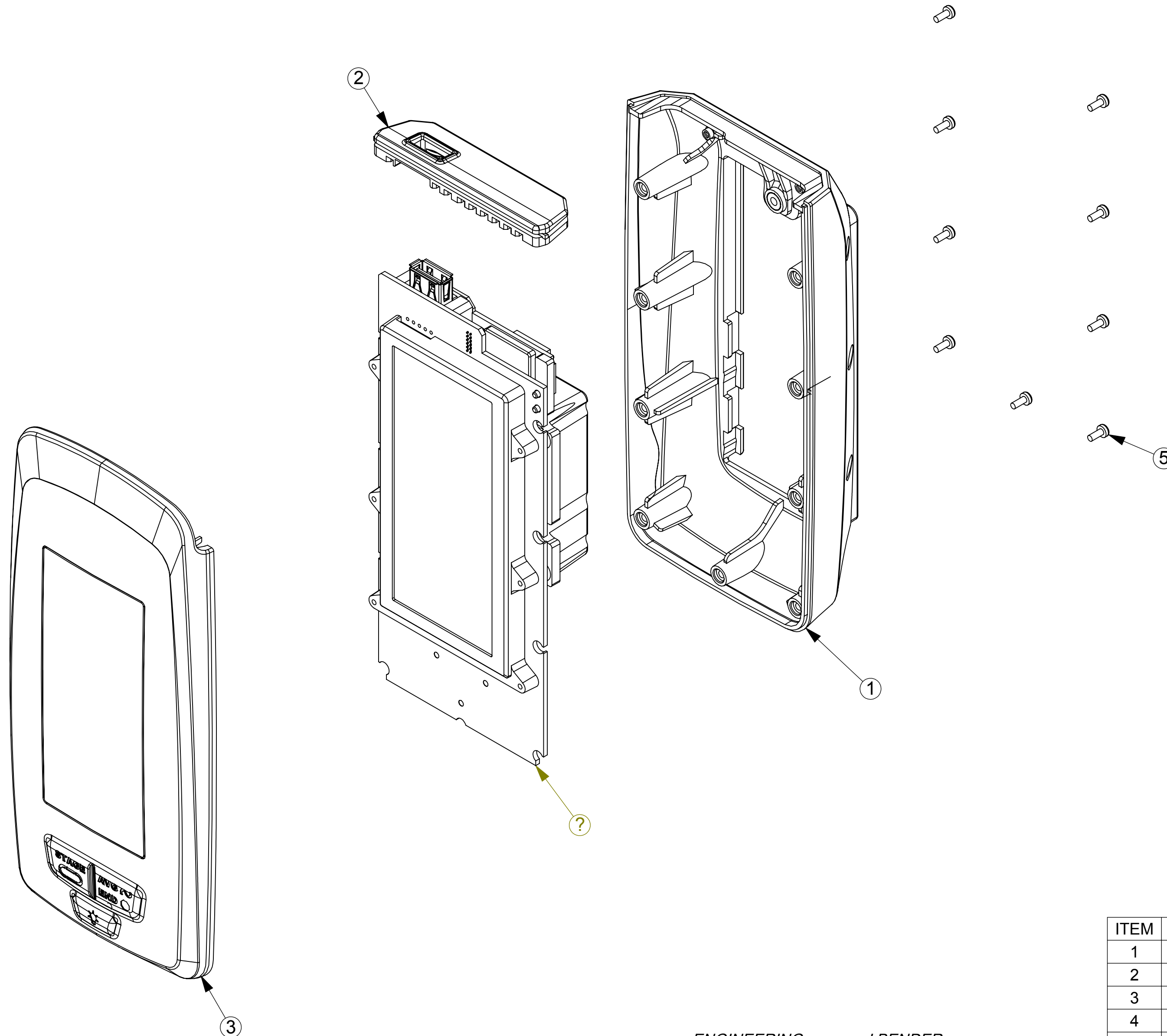

ITEM	QTY.	PART NO.	DESCRIPTION
1	1	003-5731	BOTTOM CASE W/ INSERT
2	1	002-2433	RUBBER INSERT
3	1	003-5721	TOP CASE-OVERMOLDED
4	1	003-5728	CONSOLE ELECTONICS ASSM
5	9	902-7049	SCW-PHP M2 - 0.4x5 NKL-TC

NAUTILUS
 NAUTILUS, INC.
 16400 SE NAUTILUS DRIVE, VANCOUVER, WA 98683
 CONTACT

ENGINEERING APPROVAL J. BENDER 06/25/2009
 DRAFTING C. WISHON 06/25/2009
 INDUSTRIAL DESIGN J. GETTLE 06/25/2009
 APPROVAL 06/25/2009

DESIGNED H. TAVAKOLI
 DRAWN C. WISHON
 DATE 04/29/09

TITLE: **CONSOLE ASSEMBLY**
 SIZE: **C** PART NO. **002-2438** REV. **A**